

**DOT PRINTER
SP717 / 747 SERIES**

Hardware Manual



**Federal Communications Commission
Radio Frequency Interference
Statement**

This device complies with Part 15 of FCC Rules. Operation is subject to the following two conditions:

- (1) This device may not cause harmful interference, and
- (2) this device must accept any interference received, including interference that may cause undesired operation.

FCC CAUTION

Changes or modifications not expressly approved by the party responsible for compliance could void the user's authority to operate the equipment.

For compliance with the Federal Noise Interference Standard, this equipment requires a shielded cable.

For RF interference suppression, if a ferrite core is provided with this device, affix it to the interface cable.

NOTE:

This equipment has been tested and found to comply with the limits for a Class A digital device, pursuant to Part 15 of the FCC Rules. These limits are designed to provide reasonable protection against harmful interference when the equipment is operated in a commercial environment. This equipment generates, uses and can radiate radio frequency energy and, if not installed and used in accordance with the instruction manual, may cause harmful interference to radio communications. Operation of this equipment in a residential area is likely to cause harmful interference in which case the user will be required to correct the interference at his own expense.

CAN ICES-3 (A) / NMB-3 (A)

Caution Symbol



This symbol is placed near the print head to indicate that it may be hot. Never touch the print head immediately after the printer has been used. Let the print head cool for a few minutes before touching it.



This symbol is placed near the cutter (auto cutter or manual cutter tear bar). Never touch the cutter blade, as you could injure your fingers.



This symbol label or stamp is placed near the screws securing the case, which should not be opened by individuals other than service personnel. Individuals, other than service personnel, should not remove these screws.



High voltage areas in the case can be dangerous.
This symbol is placed near the peripheral drive connector.
Do not connect this to a telephone.

Trademark acknowledgments

SP700 : Star Micronics Co., Ltd.

Notice

- All rights reserved. Reproduction of any part of this manual in any form whatsoever, without STAR's express permission is forbidden.
- The contents of this manual are subject to change without notice.
- All efforts have been made to ensure the accuracy of the contents of this manual at the time of going to press. However, should any errors be detected, STAR would greatly appreciate being informed of them.
- The above notwithstanding, STAR can assume no responsibility for any errors in this manual.
- IOS is a trademark or registered trademark of Cisco in the U.S. and other countries and is used under license.
- Android is a trademark of Google Inc.
- Windows is registered trademarks of Microsoft Corporation.

TABLE OF CONTENTS

1. Outline	1
2. Unpacking and Installation	2
2-1. Unpacking	2
2-2. Notes about Installation	2
2-3. Handling Care	3
2-4. Maintenance	3
3. Parts Identification and Nomenclature	4
4. Setup	5
4-1. Connecting the Cable to the PC	5
4-2. Connecting the Cable to the Printer	6
4-3. Connecting to a Peripheral Unit	9
4-4. Connecting the Power Cord	10
4-5. Turning Power On	11
4-6. Installing the Cable	12
4-7. Switch Blind Installation	12
5. Loading the Ribbon Cartridge and Paper	13
5-1. Loading the Ribbon Cartridge	13
5-2. Loading the paper	14
5-3. Installing the Roll Paper Guide	16
5-4. Setup Precautions	17
6. Control Panel and Other Functions	19
6-1. Control Panel	19
6-2. Basic Indicators	19
6-3. Errors	20
6-4. Adjustment Mode	22
7. Preventing and Clearing Paper Jams	28
7-1. Preventing Paper Jams	28
7-2. Removing Paper Jam	28
7-3. Releasing a Locked Cutter (Auto Cutter Mode only)	29

1. Outline

The SP700 Series Serial Impact Dot Matrix Printer is designed for use with electronic instruments such as POS, banking equipment, computer peripheral equipment, etc.

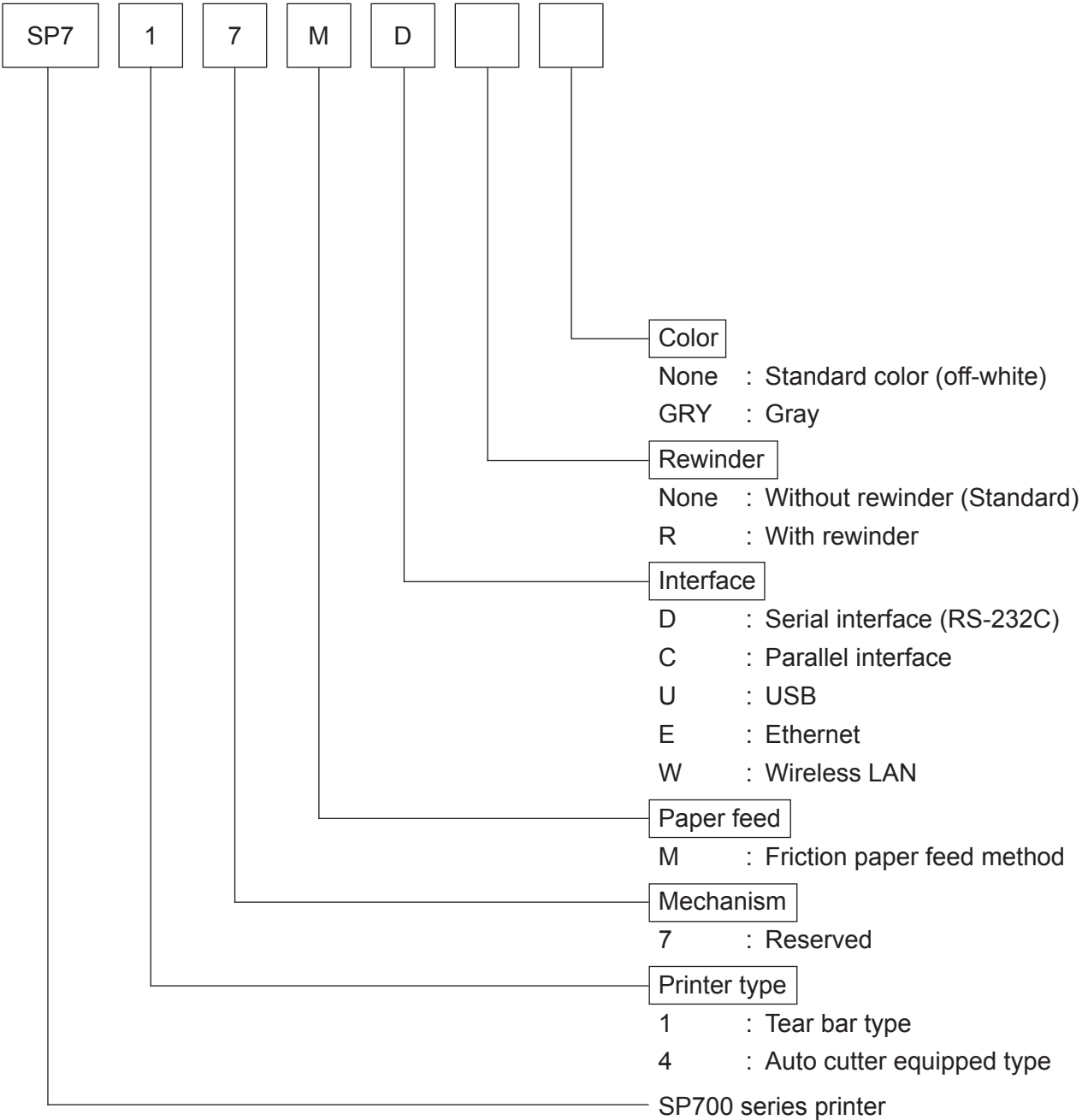

2. Unpacking and Installation

2-1. Unpacking

After unpacking the unit, check that all the necessary accessories are included in the package.

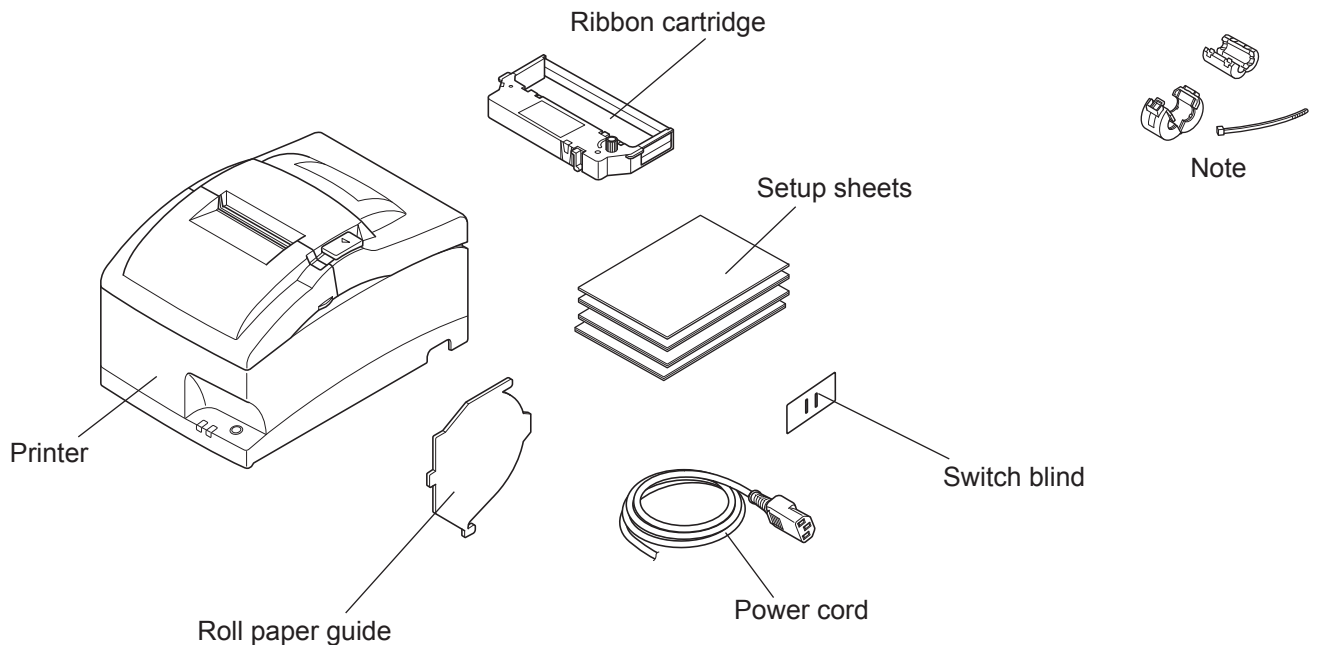

Note: The ferrite core and fastener provided with your printer depend on your printer configuration.

2-2. Notes about Installation

1. Choose a firm, level surface where the printer will not be exposed to vibration.
2. Make sure that the printer is connected to a reliable power outlet. It should not be on the same electric circuit as copiers, refrigerators, or other appliances that cause power spikes.
3. The power outlet you plan to connect to for power should be nearby and unobstructed.
4. Make sure that the printer is not exposed to direct sunlight.
5. Make sure that the printer is well away from heaters and other sources of extreme heat.
6. Do not locate the printer in a badly ventilated or dusty environment.
7. Make sure that the room where you are using the printer is not too humid.
8. This device employs a DC motor and switches that have an electrical contact point. Avoid using the device in environments where silicon gas can become volatile.
9. Use the printer within the boundaries indicated in the environmental requirements. Even when the ambient temperature and humidity are within the specifications, avoid radical changes in environmental conditions. The suitable operating temperature range is as follows:
Operating temperature: 0°C to 50°C
10. When disposing of the printer, obey local regulations.

2-3. Handling Care

1. Be careful not to drop paper clips, pins or other foreign matter into the unit as these cause the printer to malfunction.
2. Do not attempt to print when either paper or ribbon cartridge is not located in the printer, otherwise the print head can be damaged.
3. Do not open the cover while printing.
4. Do not touch the print head immediately after printing as it gets very hot.
5. Use only roll paper that is not glued to the core.
6. When the paper end mark appears on the paper, replace the roll paper before it runs out.

2-4. Maintenance

Essentially, your printer is a robust piece of equipment, but should be treated with a modicum of care in order to avoid malfunctions. For example:

1. Keep your printer in a “comfortable” environment. Roughly speaking, if you feel comfortable, then the environment is suitable for your printer.
2. Do not subject the printer to physical shocks or excessive vibration.
3. Avoid over-dusty environments. Dust is the enemy of all precision mechanical devices.
4. To clean the exterior of the printer, use a cloth barely dampened with either water with a little detergent or a little alcohol, but do not allow any liquid to fall inside the printer.
5. The interior of the printer may be cleaned with a small cleaner or a compressed-air aerosol (sold for this purpose). When performing this operation, be sure not to bend or damage any cable connections or electronic components.

3. Parts Identification and Nomenclature

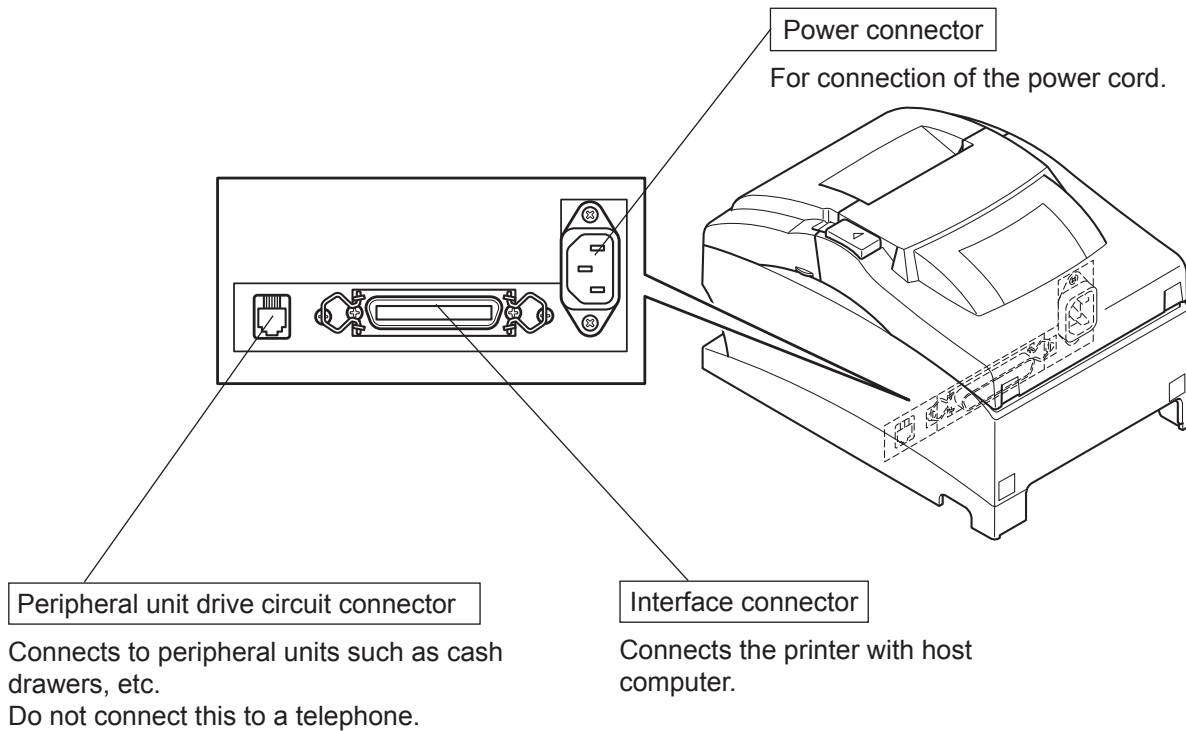
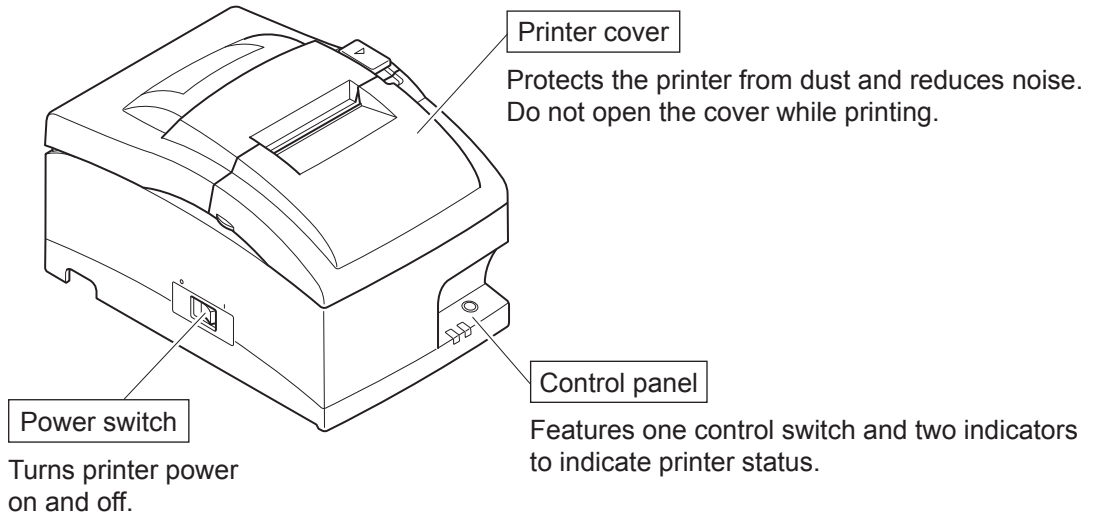

4. Setup

4-1. Connecting the Cable to the PC

4-1-1. Parallel Interface Cable

Connect the parallel interface cable to a parallel port of your PC.

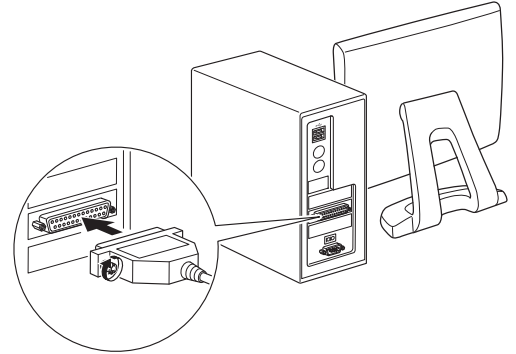

4-1-2. RC-232 Interface Cable

Connect the RC-232 interface cable to a RS-232 port of your PC.

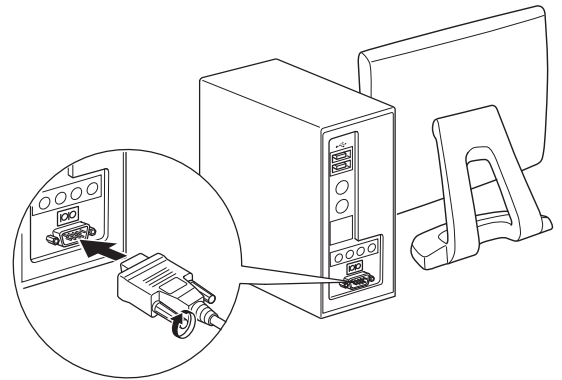

4-1-3. USB Interface Cable

Connect the USB interface cable to a USB port of your PC.

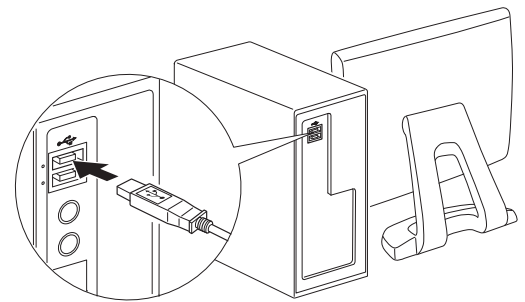

4-1-4. Ethernet Interface cable

Connect the ethernet interface cable to a ethernet port of your PC.

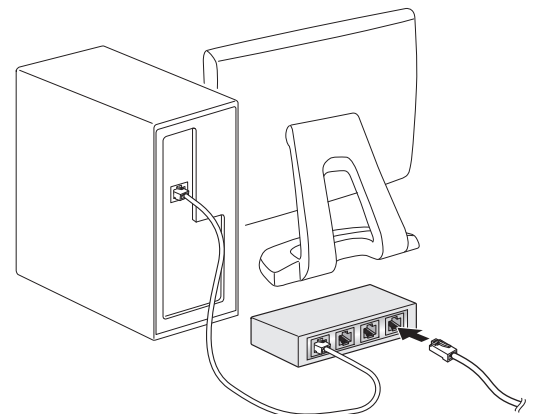

4-2. Connecting the Cable to the Printer

Note that the interface cable is not provided. Please use a cable that meets specifications.

⚠ CAUTION

Before connecting/disconnecting the interface cable, make sure that power to the printer and all the devices connected to the printer is turned off. Also make sure the power cable plug is disconnected from the AC outlet.

4-2-1. Parallel Interface Cable

- (1) Make sure the printer is turn off.
- (2) Affix the ferrite core onto the cable as shown in the illustration.
- (3) Pass the fastener through the ferrite core.
- (4) Loop the fastener around the cable and lock it.
Use scissors to cut off any excess.

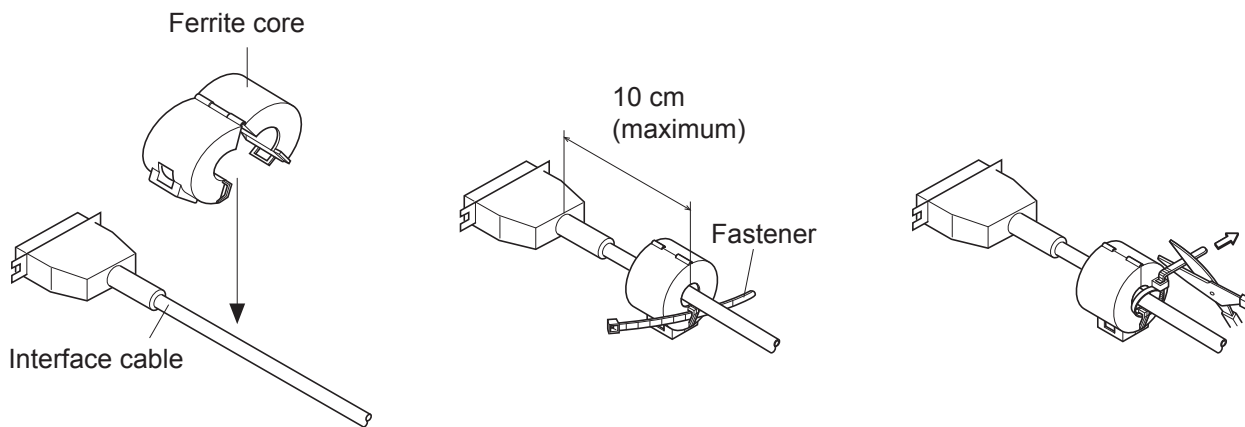
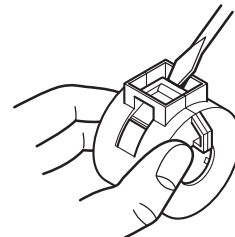

- (5) Connect the interface cable to the connector on the rear panel of the printer.
- (6) Fasten the connector clasps.

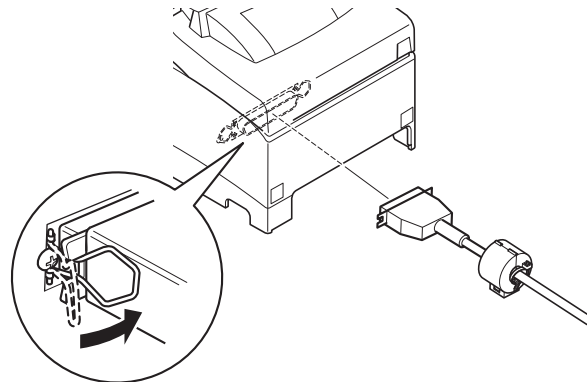

4-2-2. RS-232 Interface Cable

- (1) Make sure the printer is turn off.

⚠ CAUTION

Before connecting/disconnecting the interface cable, make sure that power to the printer and all the devices connected to the printer is turned off. Also make sure the power cable plug is disconnected from the AC outlet.

- (2) Connect the interface cable to the connector on the rear panel of the printer.
- (3) Tighten the connector screws.

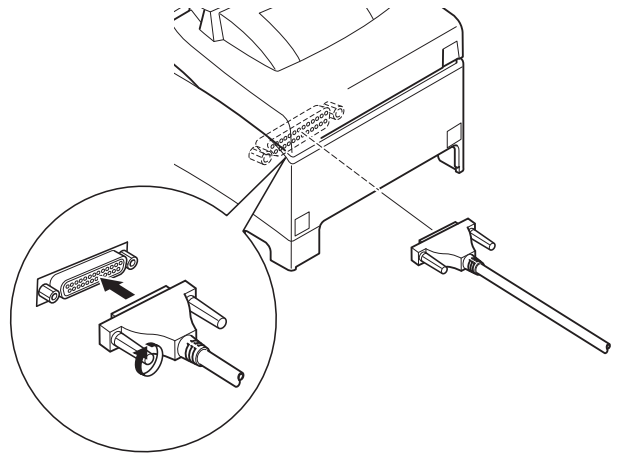

4-2-3. USB Interface Cable

Affix the ferrite core onto the USB cable as shown in the illustration below and make sure to pass the cable through the cable support as shown in the illustration.

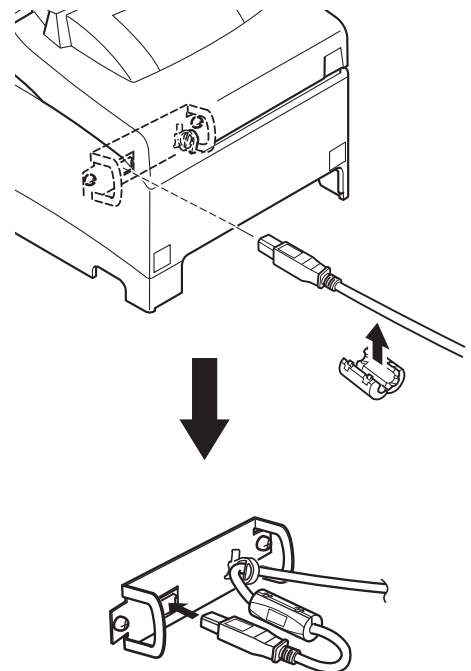

4-2-4. Connecting Ethernet Cable

If a ferrite core is included, install the ferrite core onto the Ethernet cable according to the following procedure to prevent electrical noise.

If a ferrite core is not included, perform steps (1) and (5) only.

- (1) Make sure the printer is turned off.
- (2) Affix the ferrite core onto the ethernet cable as shown in the illustration below.
- (3) Pass the fastener through the ferrite core.
- (4) Loop the fastener around the cable and lock it. Use scissors to cut off any excess.

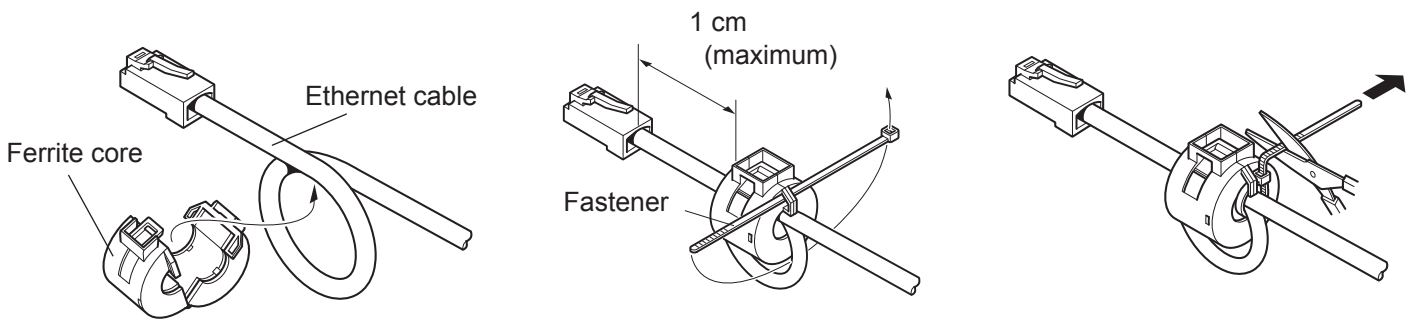
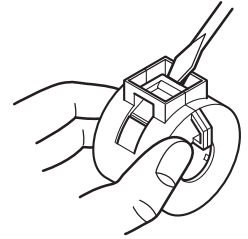

- (5) Connect the interface cable to the connector on the rear panel of the printer.

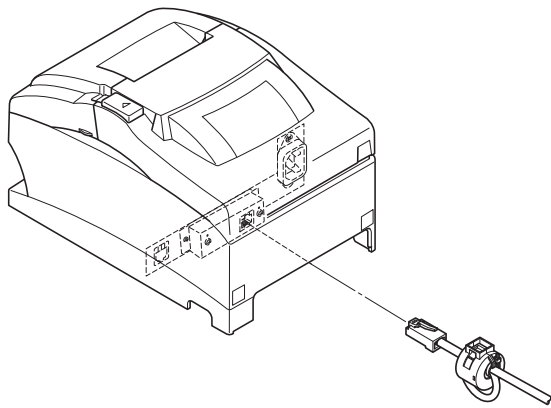

Ethernet Interface Board
IFBD-HE06

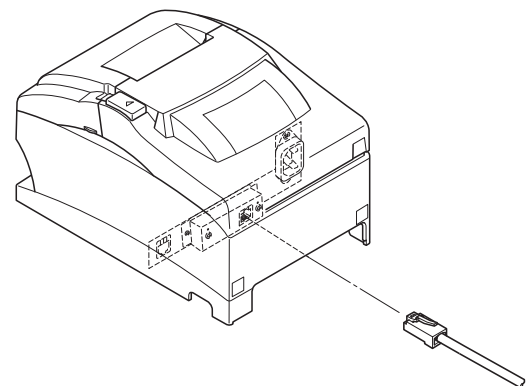

Ethernet Interface Board
IFBD-HE08

Link disconnection detection feature

The Ethernet interface model is equipped with a link disconnection detection feature. If the printer is turned on when an Ethernet cable is not connected to it, the POWER and ERROR lamps are simultaneously turned on and off at 2-second intervals to indicate the disconnection. Be sure to connect the Ethernet cable from a PC or hub to the printer, and then turn the printer on.

4-3. Connecting to a Peripheral Unit

You can connect a peripheral unit to the printer using a modular plug. Note that this printer does not come with a modular plug or wire, so it is up to you to obtain one that suits your needs.

Important!

Make sure that the printer is turned off and unplugged from the AC outlet and that the computer is turned off before making connections.

- (1) Connect the peripheral drive cable to the connector on the rear panel of the printer.

Important!

Do not connect a telephone line into the peripheral drive connector. Failure to observe this may result in damage to the printer.

Also, for safety purposes, do not connect wiring to the external drive connector if there is a chance it may carry peripheral voltage.

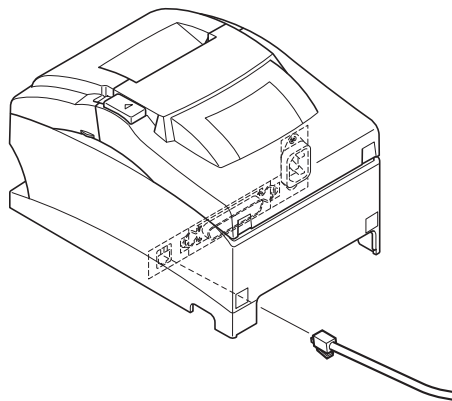

4-4. Connecting the Power Cord

Note: Before connecting/disconnecting the power cord, make sure that power to the printer and all the devices connected to the printer is turned off. Also make sure the power cable plug is disconnected from the AC outlet.

- (1) Check the label on the back or bottom of the printer to make sure its voltage matches that of the AC outlet. Also make sure the plug on the power cord matches the AC outlet.
- (2) If the power cord is not attached to the printer, plug the appropriate end into the AC inlet on the back of the printer.
- (3) Plug the power cord into a properly grounded AC outlet.

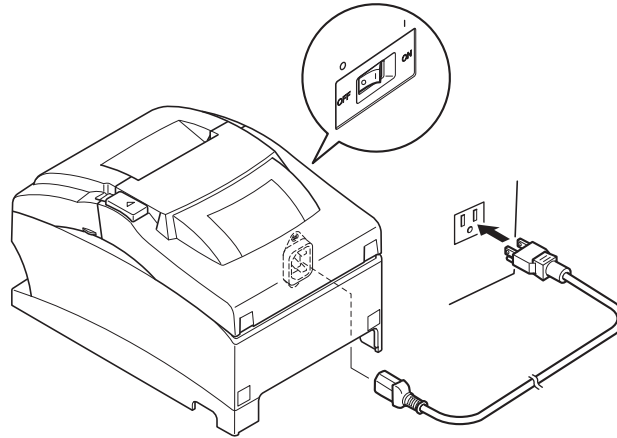

Important!

If the voltage shown on the label on the of your printer does not match the voltage for your area, contact your dealer immediately.

The power cord is designed for use with this printer only. Do not connect it to any other device.

4-5. Turning Power On

Make sure that the Power cord has been connected as described in 4-5.

Turn ON the power switch located on the front of the printer.
The POWER lamp on the control panel will light up.

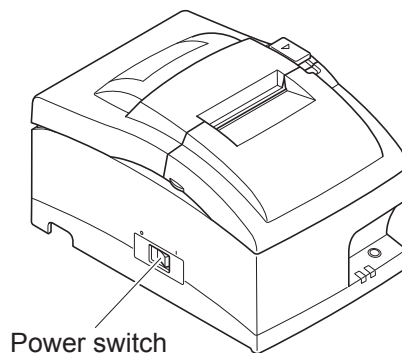

⚠ CAUTION

We recommend that you unplug the printer from the power outlet whenever you do not plan to use it for long periods. Because of this, you should locate the printer so that the power outlet it is plugged into is nearby and easy to access.

When an Switch blind is affixed to the printer above the power switch, the ON/OFF marks of the power switch may be hidden. If this occurs, remove the power cord from the outlet to turn the printer OFF.

4-6. Installing the Cable

Install the cable as shown in the diagram below.

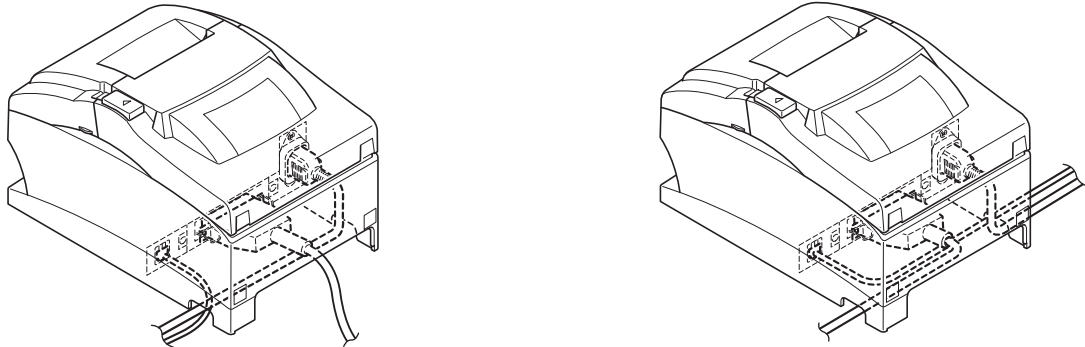

4-7. Switch Blind Installation

It is not necessary to install the switch blind. Only install it if it is necessary for you. By installing the switch blind, the following become possible.

- Preventing the power switch from being operated by mistake.
- Ensuring that other people can not easily operate the power switch.

Install the switch blind as shown in the diagram below.

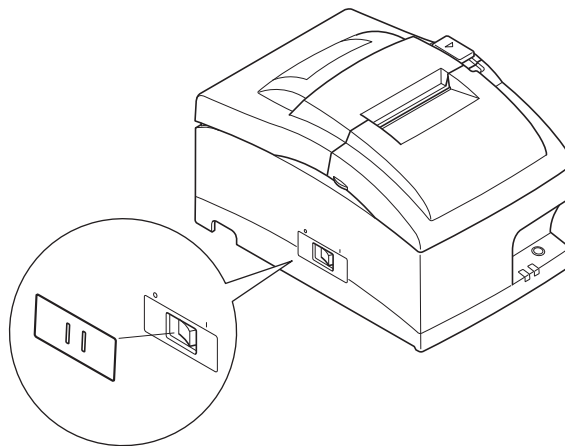

The power switch can be turned ON (I) and OFF (O) by inserting a narrow instrument (ball pen etc) in the holes in the switch blind.

Important!

We recommend that you unplug the printer from the power outlet whenever you do not plan to use it for long periods. Because of this, you should locate the printer so that the power outlet it is plugged into is nearby and easy to access.

5. Loading the Ribbon Cartridge and Paper

5-1. Loading the Ribbon Cartridge

- ① Turn off power to the printer.
- ② Open the front cover by holding the finger grips on both ends of the cover and lifting it up.

Important!

1. Do not touch the print head immediately after printing as it can be extremely hot.
2. Do not touch the cutter blade.
 - There is a cutter inside the paper outlet slot. Not only should you not put your hand in the paper outlet slot while printing is in progress, never put your hand into the outlet even when printing is not in progress.

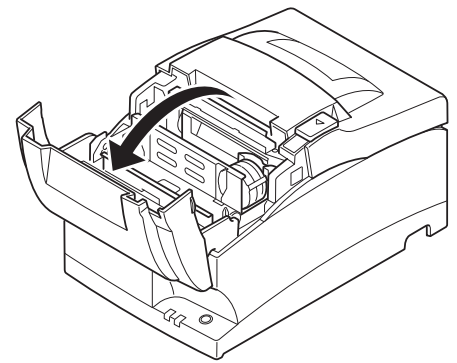
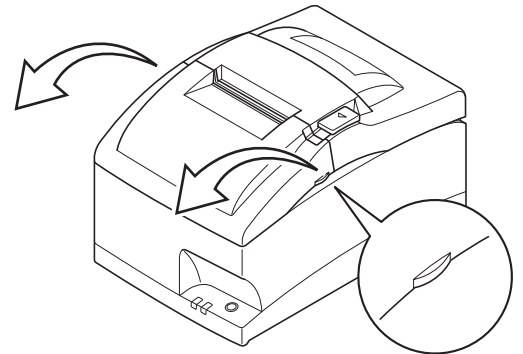

- ③ Place the ribbon cartridge in the direction shown in the figure and press it down to load it. If loading of the ribbon cartridge is not satisfactory, press down the cartridge while rotating the ribbon feed knob in the direction of the arrow.
- ④ Turn the ribbon feed knob of the ribbon cartridge in the direction of the arrow to remove slack in the ribbon.

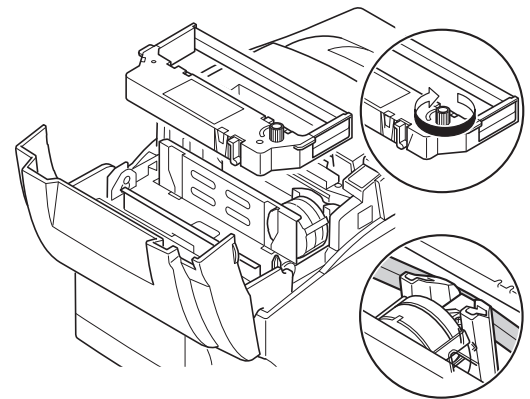

- ⑤ Close the front cover.
Note: When removing the ribbon cartridge, raise the finger grips as shown in the figure.

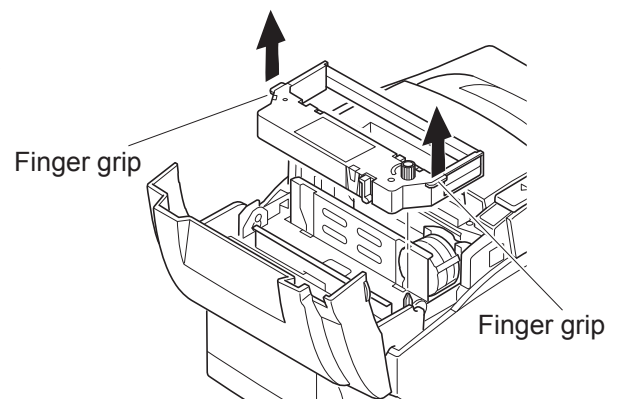

5-2. Loading the paper

- ① Open the printer cover by sliding the latch toward you.

Important!

1. Do not touch the print head immediately after printing as it can be extremely hot.
 2. Do not touch the cutter blade.
 - There is a cutter inside the paper outlet slot. Not only should you not put your hand in the paper outlet slot while printing is in progress, never put your hand into the outlet even when printing is not in progress.
-

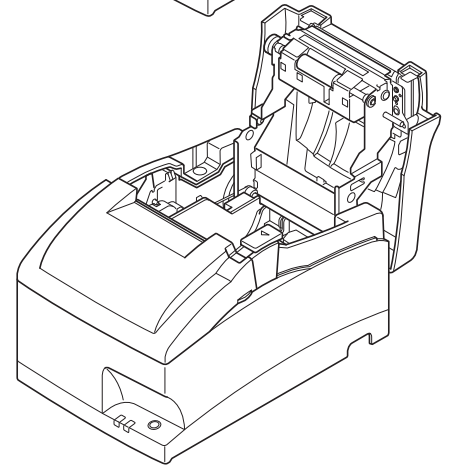
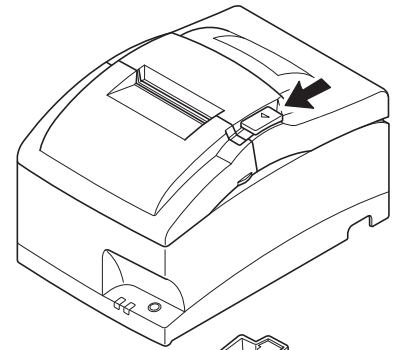

- ② While observing the direction of the roll, set the paper roll into the hollow, and pull on the leading edge of the paper toward you.

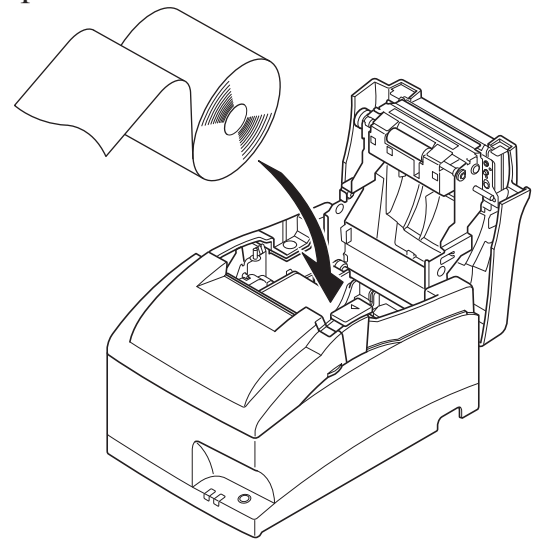
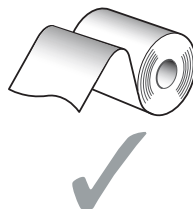

- ③ Push down both sides of the printer cover to close.
Note: Make sure that the printer cover is securely closed.

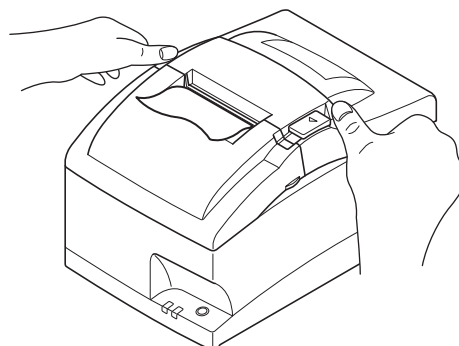
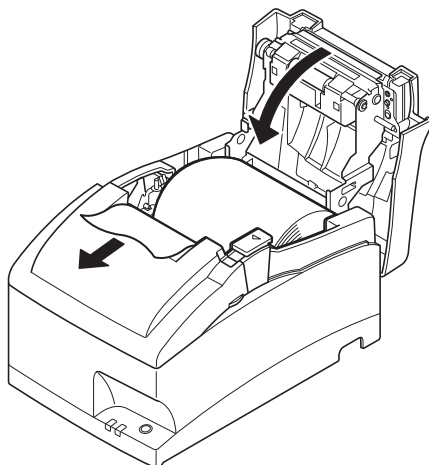

④ **Tear Bar Model:**

Tear off the paper as shown.

Auto Cutter Model:

If the printer cover is closed after turning on the power, the cutter operates automatically and the front end of the paper is cut.

Note: When the paper end mark appears on the paper, replace the roll paper before it runs out.

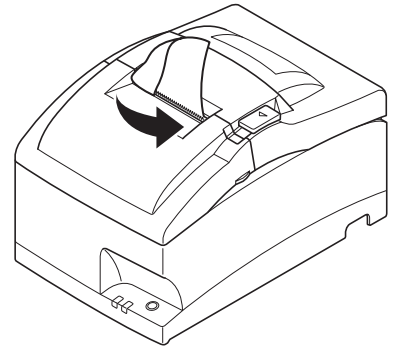

5-3. Installing the Roll Paper Guide

When using paper roll with 57.5 mm or 69.5 mm width, install the attached roll paper guide in the groove in the printer. The setting for memory switch 2-A and 2-B must be changed to change the print width.

For instructions on setting the memory switch, please refer to the separate Specification Manual.

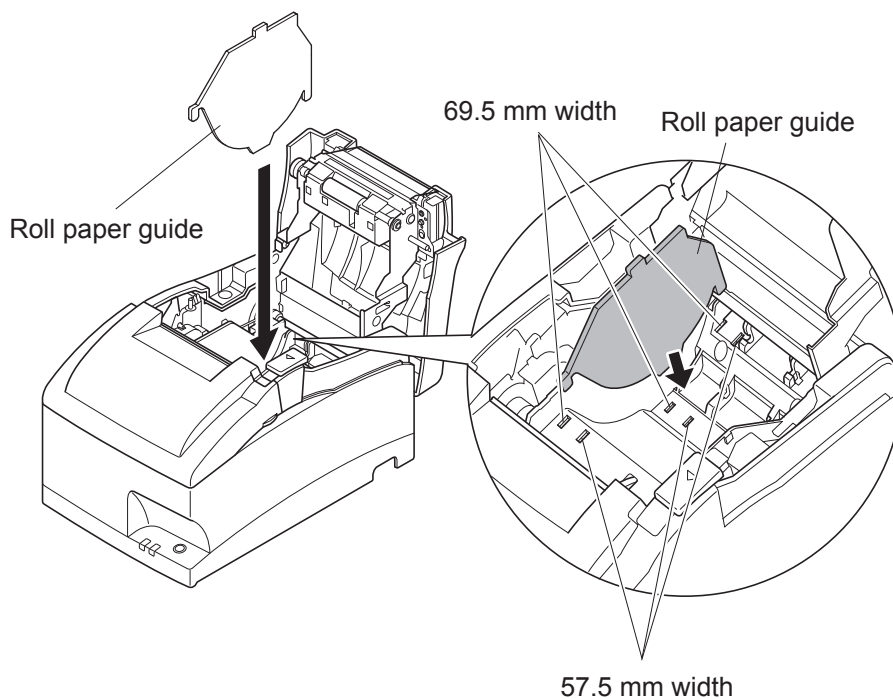

5-4. Setup Precautions

Caution Symbol



This symbol is placed near the print head to indicate that it may be hot. Never touch the print head immediately after the printer has been used. Let the print head cool for a few minutes before touching it.



This symbol is placed near the cutter (auto cutter or manual cutter tear bar). Never touch the cutter blade, as you could injure your fingers.



This symbol label or stamp is placed near the screws securing the case, which should not be opened by individuals other than service personnel.

Individuals, other than service personnel, should not remove these screws. High voltage areas in the case can be dangerous.



This symbol is placed near the peripheral drive connector. Do not connect this to a telephone.

WARNING

- ✓ Shut down your equipment immediately if it produces smoke, a strange odor, or unusual noise. Immediately unplug the equipment and contact your dealer for advice.
- ✓ Never attempt to repair this product yourself. Improper repair work can be dangerous.
- ✓ Never disassemble or modify this product. Tampering with this product may result in injury, fire, or electric shock.
- ✓ Do not touch the cutter blade.
 - There is a cutter inside the paper outlet slot. Not only should you not put your hand in the paper outlet slot while printing is in progress, never put your hand into the outlet even when printing is not in progress.
 - The printer cover can be opened when replacing the paper. However, since the cutter blade is on the inside of the printer cover, be careful not to place your face or hands too close to the cutter blade.
- ✓ During and immediately after printing, the area around the print head is very hot. Do not touch it, as you could be burned.
- ✓ Since working on the cutter may be dangerous, be sure to turn off the printer first.

⚠CAUTION

- ✓ We recommend that you unplug the printer from the power outlet whenever you do not plan to use it for long periods. Because of this, you should locate the printer so that the power outlet it is plugged into is nearby and easy to access.
- ✓ If the voltage shown on the label on the of your printer does not match the voltage for your area, contact your dealer immediately.
- ✓ Make sure that the printer is turned off and unplugged from the AC outlet and that the computer is turned off before making connections.
- ✓ Do not connect a telephone line into the peripheral drive connector.
Failure to observe this may result in damage to the printer.
Also, for safety purposes, do not connect wiring to the external drive connector if there is a chance it may carry peripheral voltage.
- ✓ Do not operate the cover open lever while pressing on the printer cover with your hand.
- ✓ Do not pull the cover open lever and open the printer cover when printing is in progress or when the auto cutter is operating.
- ✓ Do not pull out paper while the printer cover is closed.
- ✓ If liquids, foreign objects (coins and paper clips), and so on enter the printer, turn off the printer, unplug it from the AC outlet, and contact your dealer for advice. Continued use could cause a short circuit, which may result in fire or electric shock.
- ✓ Place the printer in a horizontal position when installing the paper, even if the model can be installed vertically. If the paper is installed with the printer in a vertical position, the printer will be unstable and could fall, which may result in injury.

6. Control Panel and Other Functions

6-1. Control Panel

- ①POWER lamp (Green LED)
Lights when the power is ON.
- ②FEED button
Press the FEED button to feed roll paper.
- ③ERROR lamp (Red LED)
Indicates various errors in combination with
POWER lamp.

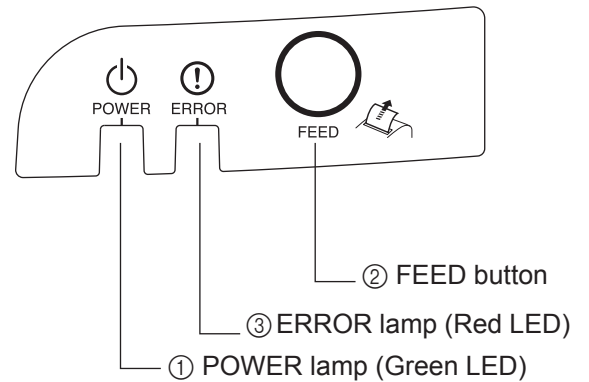

6-2. Basic Indicators

	POWER lamp	ERROR lamp	Buzzer
Power On/Off	On/Off	—	—
No Error	On	Off	—

6-3. Errors

1) Recoverable error

Error Description	POWER lamp	ERROR lamp	Buzzer	Recovery Conditions
Paper end error	On	Flashes (On: 1 sec./ Off: 1 sec.)	4 short beeps (0.13 sec.) repeated twice	*1
Printer cover open error	On	On	Beep	*2
Front cover open error	Flashes (On: 0.5 sec./ Off: 0.5 sec.)	On	Beep	*3
Head high temperature detection	Flashes (On: 1 sec./ Off: 1 sec.)	Off	None	*4
Board high temperature detection	Flashes (On: 2 sec./ Off: 2 sec.)	Off	None	*5
Cutter error (on models with cutter)	On	Flashes (On: 0.125 sec./ Off: 0.125 sec.)	3 short beeps (0.13 sec. + 0.13 sec. + 0.5 sec.)	*6
Mechanical error (other than cutter error)	On	Flashes (On: 0.25 sec./ Off: 0.25 sec.)	2 short beeps (0.13 sec. + 0.5 sec.)	*7
Black mark detection error	On	Flashes (On: 0.5 sec./ Off: 0.5 sec.)	3 short beeps (0.13 sec. + 0.13 sec. + 0.13 sec.)	*8
Link disconnection detection (Physical link disconnection)	Flashes at 2-second intervals	Flashes at 2-second intervals	—	*9
Link disconnection detection (IP address lost)	Flashes at 0.125-second intervals	Flashes at 0.125-second intervals	—	*10

*1 Automatically recovered by loading a new paper roll, then closing the printer cover.

*2 Automatically recovered by closing the printer cover.

*3 Automatically recovered by closing the front cover.

*4 Automatically the printer is recovered after the print head has cooled.
A print head temperature error is not abnormal.

*5 Automatically the printer is recovered after the board has cooled.

*6 Automatically the printer is recovered if the cutter returns to the home position after turning the power OFF and ON. Restoration is also possible with the <DLE> <ENQ> n command when in the ESC/POS mode.

Note

- 1) If the cutter doesn't return to the home position, or doesn't perform the initial movement, it cannot be recovered.
- 2) If the paper is jammed, turn the power OFF, clear the jammed paper, then turn the power ON.
- 3) When the error occurs:
STAR Mode: Non recoverable error
ESC/POS Mode: Recoverable error

- *7 Turn the power OFF, clear the jammed paper or remedy another problem and then turn the power ON. Automatically the printer is recovered if the carriage returns to the home position after turning the power OFF and ON. Restoration is also possible with the <DLE> <ENQ> n command when in the ESC/POS mode.

When the error occurs:

STAR Mode: Non recoverable error

ESC/POS Mode: Recoverable error

- *8 For paper jam errors:

Clear the jammed paper and change the paper roll if necessary.

For incorrect paper format errors:

Change the paper roll and use a paper roll with the correct black mark.

- *9 Connect an Ethernet cable. For details, see section 4-2-4. Connecting Ethernet Cable

<Ethernet interface model only>

- *10 Set the correct IP address and restart the printer.

<Ethernet interface model only>

2) Non recoverable error

Error Description	POWER lamp	ERROR lamp	Buzzer
Flash memory write error	Off	Flashes (On: 1 sec./ Off: 1 sec.)	None
Thermistor failure error	Off	Flashes (On: 0.25 sec./Off: 0.25 sec.)	2 short beeps (0.13 sec. + 0.5 sec.)
Power supply error	Off	Flashes (On: 2 sec./ Off: 2 sec.)	None
CPU error	Off	On	One long beep (2 sec.)
RAM R/W error	Off	On	None

Note

If a non-recoverable error occurs, turn the power OFF, wait at least 10 seconds, and turn the power back ON. If the non-recoverable error continues to be indicated, consult a dealer for repairs.

6-4. Adjustment Mode

There are the following seven adjustment modes.

The device will enter the adjustment mode if you turn it on while pressing the FEED switch.

- (1) The Self Printing Mode is entered by releasing the FEED switch after the buzzer sounds once. (Refer to Section 6-4-1.)

↓
(Holding down for 2 more seconds)

- (2) Adjusting the Dot Alignment Mode is entered by releasing the FEED switch after the buzzer sounds twice. (Refer to Section 6-4-2.)

↓
(Holding down for 2 more seconds)

- (3) The Hexadecimal Dump Mode is entered by releasing the FEED switch after the buzzer sounds three times. (Refer to Section 6-4-3.)

↓
(Holding down for 2 more seconds)

- (4) The Black Mark Sensor Alignment Mode is entered by releasing the FEED switch after the buzzer sounds four times. (Refer to Section 6-4-4.)

↓
(Holding down for 2 more seconds)

- (5) The Near End Sensor Adjustment Mode is entered by releasing the FEED switch after the buzzer sounds five times. (Refer to the separate Specifications Manual for details.)

↓
(Holding down for 2 more seconds)

- (6) The Memory Switch Manual Setting Mode is entered by releasing the FEED switch after the buzzer sounds six times. (Refer to the separate Specifications Manual for details.)

↓
(Holding down for 2 more seconds)

- (7) The Memory Switch Override Mode is entered by releasing the FEED switch after the buzzer sounds seven times. (Refer to the separate Specifications Manual for details.)

↓
(Holding down for 2 more seconds)

↓
Returns to (1).

6-4-1. Self Printing Mode

Self-printing will be performed to print the Ver. No. and printer settings. ASCII-printing will be repeated when the FEED switch is held continuously at the end of ASCII-printing. The self-printing mode will end automatically when the FEED button is released at the end of ASCII-printing.

```
** 57
```

```
Interface : Parallel
```

```
Memory Switch
```

```
FEDCBA9876543210 HEX.
```

```
<0> 0000000000000000 0000
```

```
<1> 0000000000000000 0000
```

```
<2> 0000000000000000 0000
```

```
<3> 0000000000000000 0000
```

```
<4> 0000000000000000 0000
```

```
<5> 0000000000000000 0000
```

```
<6> 0000000000000000 0000
```

```
<7> 0000000000000000 0000
```

```
00000000 0000
```

```
000 0000
```

```
<0> 4 = Model : 2
```

```
<0> B-A = ESC 4 (Ank)
```

```
<0> 9 = <SP> Red : Valid
```

```
<0> 2-3 = <FF> : Form Feed
```

```
<1> 8 = Black Mark : Invalid
```

```
<1> 4 = Zero Style : Normal Zero
```

```
<1> 0-3 = International: USA
```

```
<7> 0-B = Print Width : 210 Dots
```

- (3) To adjust, use the FEED switch to select the adjustment pattern from the printout with the smallest gap between the first printing pass and the return printing pass. Press the FEED switch once to specify the first adjustment pattern, twice to specify the second adjustment pattern, and so on up to seven times to specify the seventh adjustment pattern.

At the number that you want to specify, press and hold (2 seconds) the FEED switch until the long buzzer sounds. This will specify the setting value. (For example, if you want to select the eighth pattern from the top, press the FEED switch seven times. Then, at the eighth pattern, press and hold (2 seconds) the FEED switch until the long buzzer sounds.) There are only twenty three adjustment patterns. The buzzer will sound each time the FEED switch is pressed. However, if you press the FEED switch more than twenty three times, a warning alert will sound.

- (4) If there is no matching pattern among the adjustment patterns, perform the “Backward” or “Forward” operation described below in order to print a printing pattern in which the dot alignment settings are changed. Then, repeat step (3).

Backward:

Press and hold the FEED switch for 2 to 4 seconds. The buzzer will beep, and the printer will print a pattern in which the forward is adjusted more leftward of the presently indicated pattern and the backward is adjusted more rightward.

Forward:

Press and hold the FEED switch for 4 seconds or longer. The buzzer will beep-beep, and the printer will print a pattern in which the forward is adjusted more rightward of the presently indicated pattern and the backward is adjusted more leftward.

- (5) After selecting the adjustment pattern, the setting value is stored in the non-volatile memory. A printout similar to the one below with the selected adjustment pattern highlighted and the message “Adjust Completed!” will be printed.

Note: Before the printout is printed, the setting value is stored in the non-volatile memory of the printer after the adjustment pattern has been selected and the long buzzer sounds. During this period, do not set the power switch to off. If this power switch is set to off when the setting value is being stored in the non-volatile memory, the setting value for the adjustment pattern and all of the memory switch settings will be reset.

```
Lv.55
| | | | | | | | | | | | | | | | | | | | | |
Lv.56
| | | | | | | | | | | | | | | | | | | | | |
* Lv.57
| | | | | | | | | | | | | | | | | | | | | |
Lv.58
| | | | | | | | | | | | | | | | | | | | | |
Lv.59
| | | | | | | | | | | | | | | | | | | | | |
Adjust Completed!
```

- (6) The long buzzer sounds once more and the setting value is automatically set. The adjusting the dot alignment mode is complete.

6-4-3. Hexadecimal Dump Mode

Each of the signals sent from the computer to the printer will be printed out in hexadecimal code. This function allows you to check if a control code sent to the printer by the program being used is correct or not. The last line is not printed if its data is less than one full line. However, if the FEED switch is pressed, the last line will be printed. To turn off the mode, it is necessary to turn off the printer completely.

```
//// Hexadecimal Dump ////  
  
00 01 02 03 04 05 06 07      .....  
08 09 0A 0B 0C 0D 0E 0F      .....  
10 11 12 13 14 15 16 17      .....  
18 19 1A 1B 1C 1D 1E 1F      .....  
20 21 22 23 24 25 26 27      !"#$%&'  
28 29 2A 2B 2C 2D 2E 2F      ()*+,-./  
30 31 32 33 34 35 36 37      01234567  
38 39 3A 3B 3C 0A           89:;<.
```

6-4-4. Black Mark Sensor Alignment Mode

1. Turn the printer off and unplug the power cord.
2. Place the printer upright as shown below to remove the screws and remove the dip switch cover from the bottom of the printer. Be sure to place the printer upright because you will not be able to properly adjust the printer if it is placed on its side.

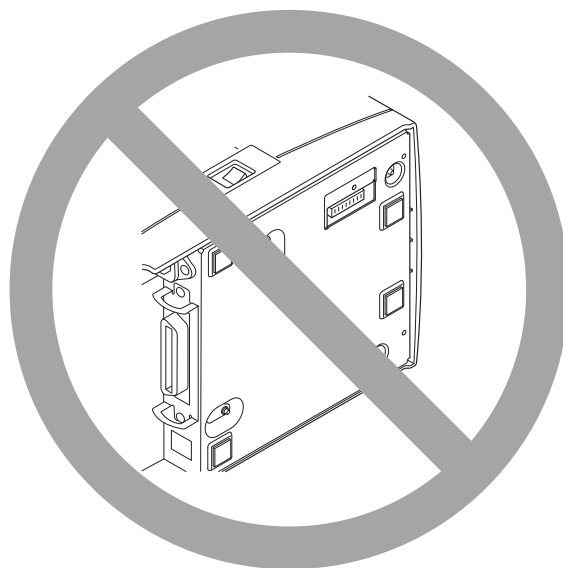
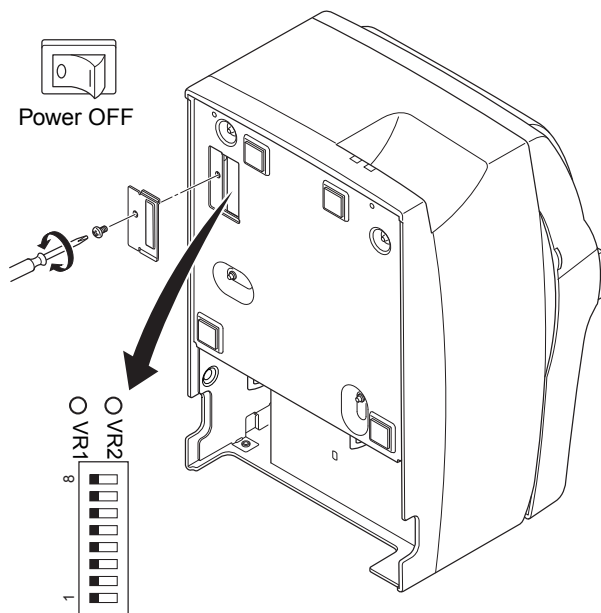

3. Since it is adjusted by rotating the volume VR2, check the position of the volume. Prepare a small slotted screwdriver that will fit in the hole.
4. Set the roll paper not for black mark.
5. Enter the black mark sensor adjustment mode according to the procedure described Section 6-4.
6. Rotate the volume VR2 using micro screwdriver, to adjust it to a position whereat both the ERROR (red LED) and the POWER (green LED) lamps light.
7. Turn the power OFF.

This completes the black mark sensor adjustment.

7. Preventing and Clearing Paper Jams

7-1. Preventing Paper Jams

The paper should not be touched during ejection and before it is cut.

Pressing or pulling the paper during ejection may cause a paper jam, paper cutting failure or line feed failure.

7-2. Removing Paper Jam

If a paper jam occurs, clear it as described below.

(1) Set the power switch to off to turn off power to the printer.

(2) Push the cover open lever, and open the printer cover.

If the printer cover will not open on an auto cutter model, it means that the auto cutter is not in the home position (or locked). In this case, return the auto cutter to the home position by following the instructions provided in Section 7-3.

(3) Remove the jammed paper.

⚠ CAUTION

Take care not to damage the printer when removing the jammed paper.

(4) Position the roll paper straight and close the printer cover gently.

Note 1: Make sure that the paper is positioned straight. If the printer cover is closed with the paper skewed, a paper jam may result.

Note 2: Lock the printer cover by pressing down on the sides. Do not try to close it by pressing down on the center. The cover may not lock properly.

(5) Set the power switch to on to turn on power to the printer. Make sure that the ERROR LED is not lit.

Note: While the ERROR LED is lit, the printer will not accept any commands such as the print command, so make sure that the printer cover is locked properly.

7-3. Releasing a Locked Cutter (Auto Cutter Mode only)

If the auto cutter locks up or fails to cut the paper, follow the steps below.

⚠ WARNING

Since working on the cutter may be dangerous, be sure to turn off the printer first.

- (1) Set the power switch to OFF to turn off the printer.
- (2) Ordinarily, a locked cutter will recover automatically by closing all the covers and turning the power back ON.

Recovery means that the locked cutter has been released, so steps (3) and thereafter are unnecessary. If the cutter has not recovered, proceed to step (3).

- (3) Pull the cover open lever towards you, and open the printer cover. The printer cover may not open due to the cutter being locked. In this case, follow steps (4) and (5) to first open the front cover and remove the tear bar. If the printer cover opens, proceed to step (6).

Note: Since the print head is hot immediately after printing, be sure not to touch it. On an auto cutter model, a paper cutter is located at the paper outlet slot. Be careful not to touch the cutter blade.

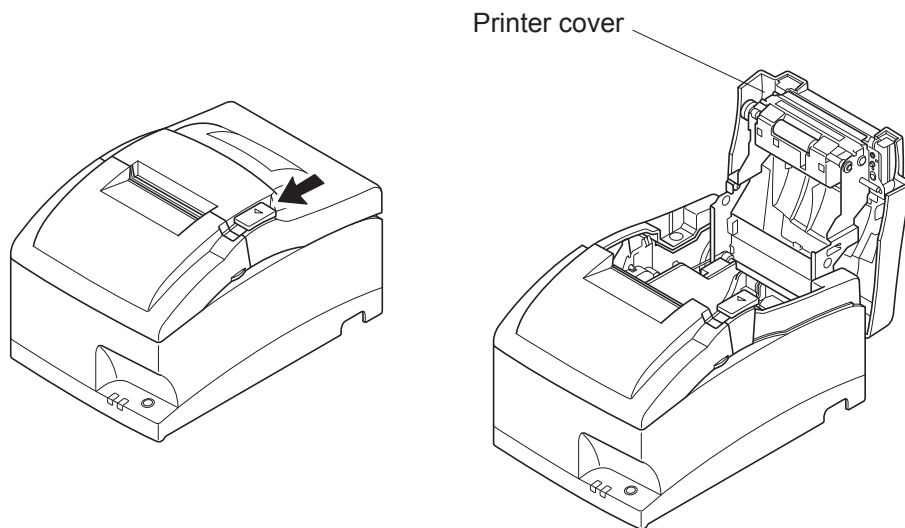

- (4) Open the front cover by holding the finger grips on both ends of the cover and lifting it up.
- (5) Remove the two screws to remove the tear bar.

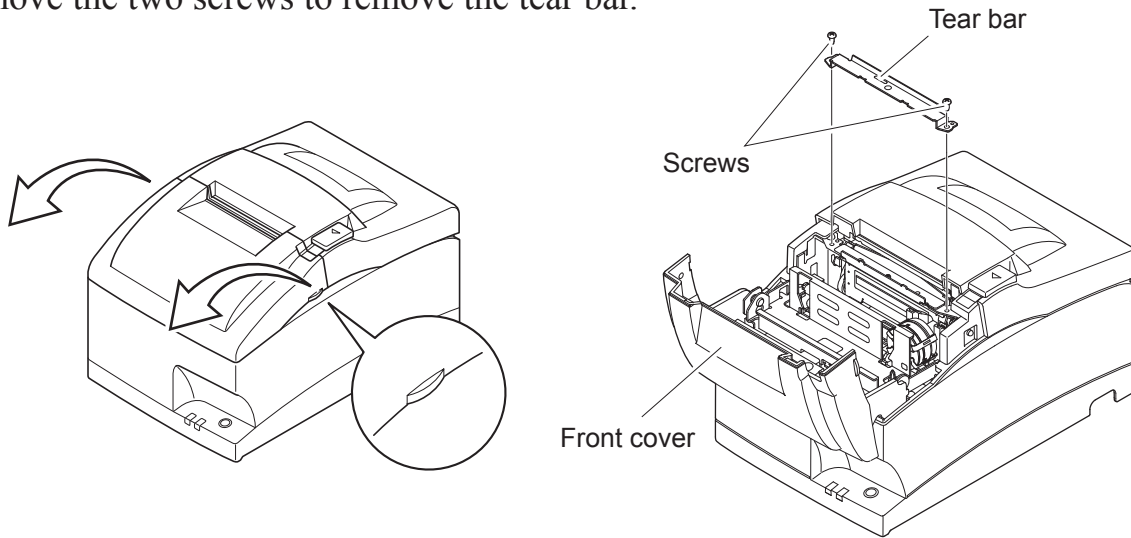

- (6) After you have opened the printer cover, remove the four screws to remove the printer cover and reveal the cutter.

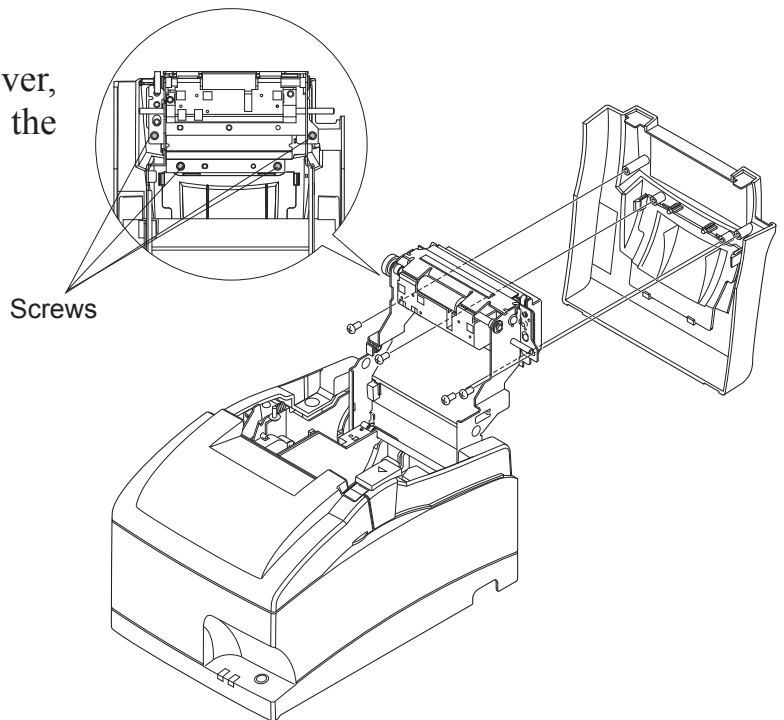

- (7) If the cutter is locked, insert a Phillips screwdriver into the Phillips screw hole on the side of the cutter, and turn it in the direction of the arrow shown below, in order to return the cutter to its normal position.
- (8) Reinstall the printer cover by tightening its screws.
- (9) Reinstall the tear bar by tightening its screws.

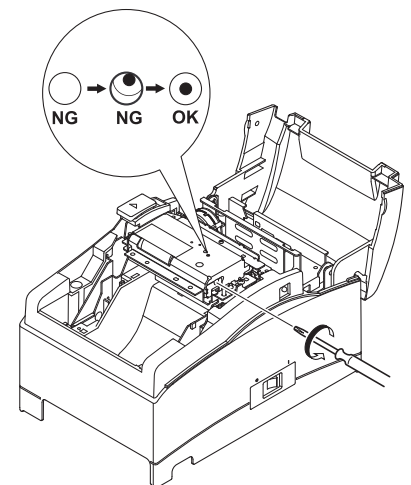



URL: <http://www.star-m.jp/eng>

Rev. 1.3